

# BRCF

## YATAY ATIŞLI RADYAL ÇATI FANI Motor Hava Akımının Dışında



Egzoz fanları olarak endüstride ve yaşamsal alanlarda sıcak baca gazlarının atılmasında sorunsuz çalışırlar. Maksimum taşınan hava sıcaklığı 120°C.

### Teknik Resim

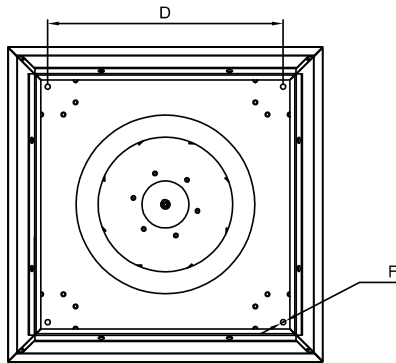
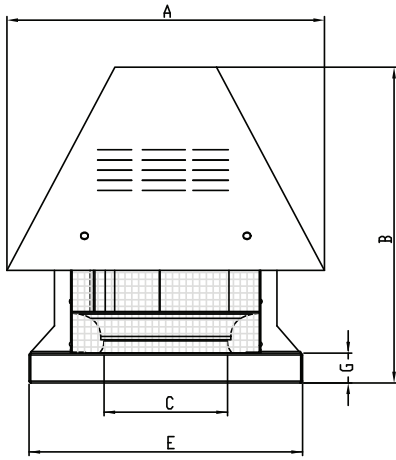

#### MALZEME

: Gövdesi; Elektrostatik toz boyalı sac  
Radyal Fan; geriye eğimli kanat yapısı ile  
DKP sacdan üretilmiştir.

#### YALITIM SINIFI

: Class F

#### MAX. HAVA TAŞINIMI

: 120°C

#### STANDART

: EN 60335-1, EN 60335-2-80, EN 12101-3

#### HIZ KONTROLÜ

: Opsiyonel kontrol cihazlarıyla sağlanabilir.

#### KULLANIM ALANLARI

: BRCF serisi fanlar yaşamsal endüstriyel ve ticari alanlarda; özellikle daha yüksek sıcaklıkta havanın taşınması gereken uygulamalarda, duman tahliye havalandırma sistemlerinde mükemmel çözümler sunarlar. Örneğin; kafeler, restoranlar, spor salonları, alışveriş merkezleri, hastaneler, fabrikalar, ofisler vs.

### Aksesuarlar



BSC-F

TİP	A	B	C	D	E	F	G
BRCF 280	524	505	165	354	404	10	44
BRCF 315	593	546	185	404	454	10	44
BRCF 355	655	546	234	450	500	10	44
BRCF 400	655	574	270	450	500	12	44
BRCF 450	730	568	282	530	580	12	44
BRCF 500	800	665	320	590	640	12	44
BRCF 560	856	723	360	650	700	12	44
BRCF 630	986	888	448	660	730	12	54
BRCF 710	1080	958	450	710	780	12	54
BRCF 800	1190	1130	542	850	900	12	54

Ölçüler mm cinsindedir.

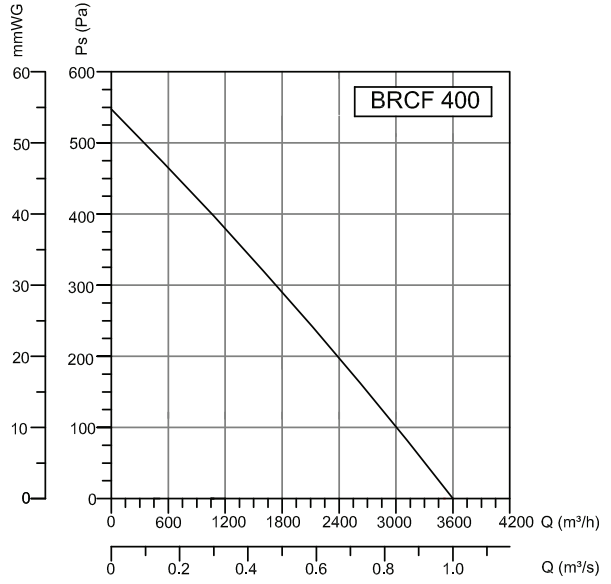
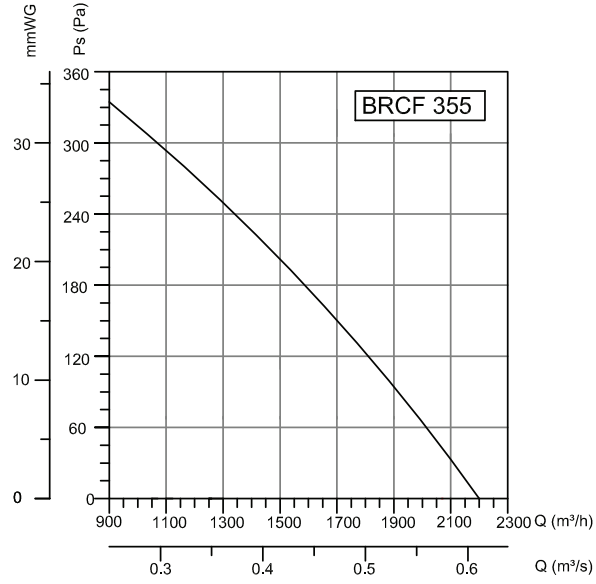
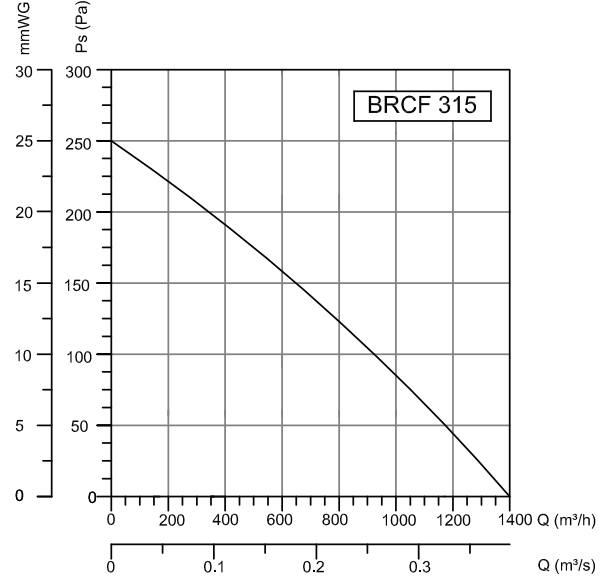
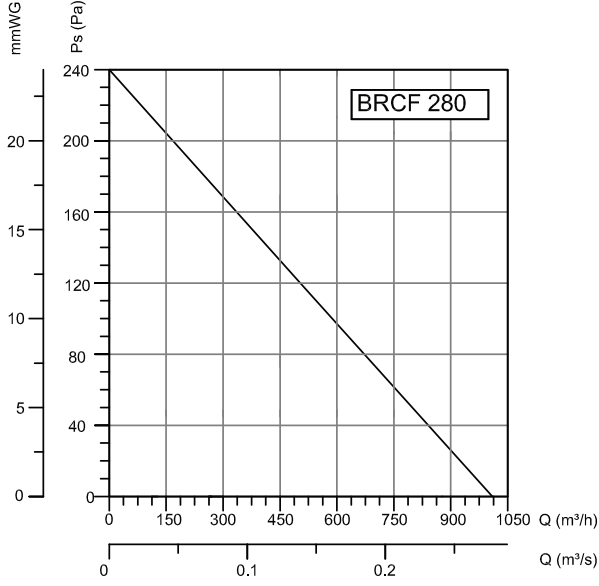

TİP	VOLTAJ	FREKANS	GÜÇ	AKIM	DEVİR	DEBİ	SES SEVİYESİ	AĞIRLIK
	V	Hz	KW	(A)	d/d	m³/h	dB(A)	kg
BRCF 280M / BRCF 280T	230/380	50	0,37	2,6/1,15	1400	1000	42	35
BRCF 315M / BRCF 315T	230/380	50	0,37	2,6/1,15	1400	1415	44	42
BRCF 355M / BRCF 355T	230/380	50	0,37	2,6/1,15	1400	2200	45	50
BRCF 400M / BRCF 400T	230/380	50	0,55	3,3/1,5	1400	3600	48	55
BRCF 450M / BRCF 450T	230/380	50	0,75	4,6/2	1400	4400	55	62
BRCF 500M / BRCF 500T	230/380	50	1,1	7,1/2,6	1400	8500	60	68
BRCF 560M / BRCF 560T	230/380	50	1,5	9,3/3,5	1400	10000	65	75
BRCF 630T	380	50	3	6,45	1000	11200	80	127
BRCF 710T	380	50	4	8,2	1000	12800	83	150
BRCF 800T	380	50	7,5	15,3	1000	16000	85	216

# ÇATI FANLARI

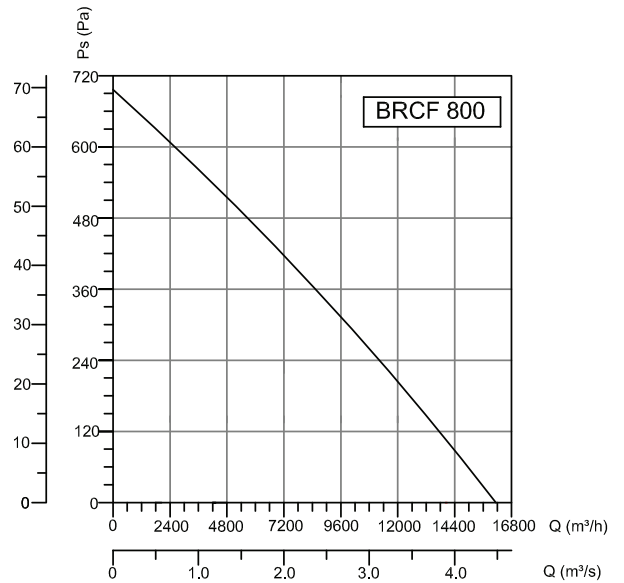
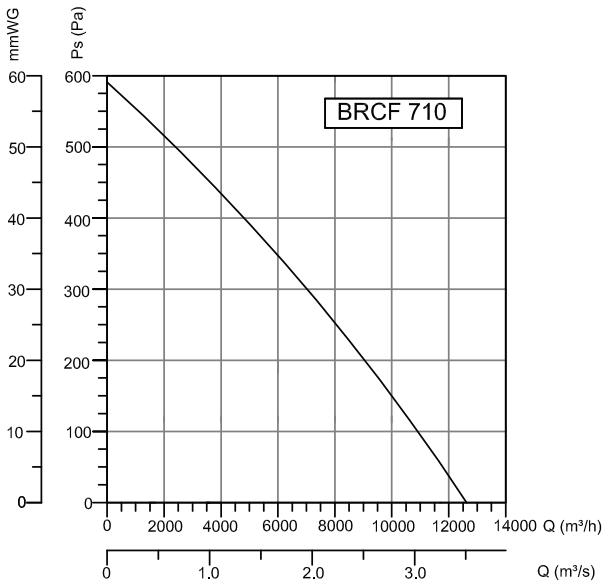
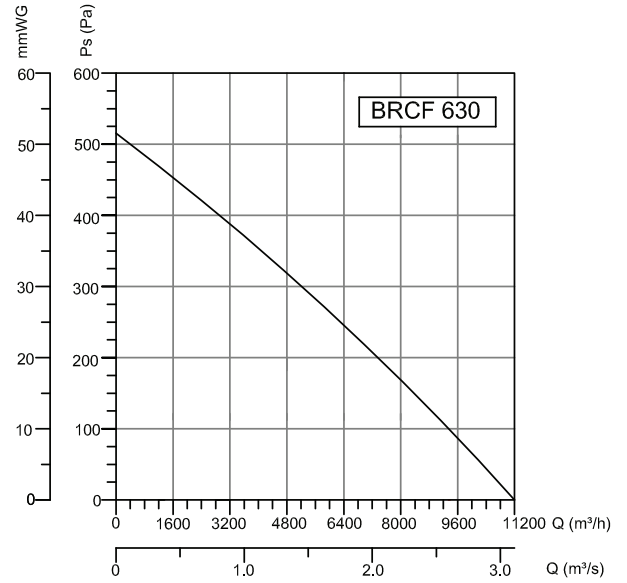
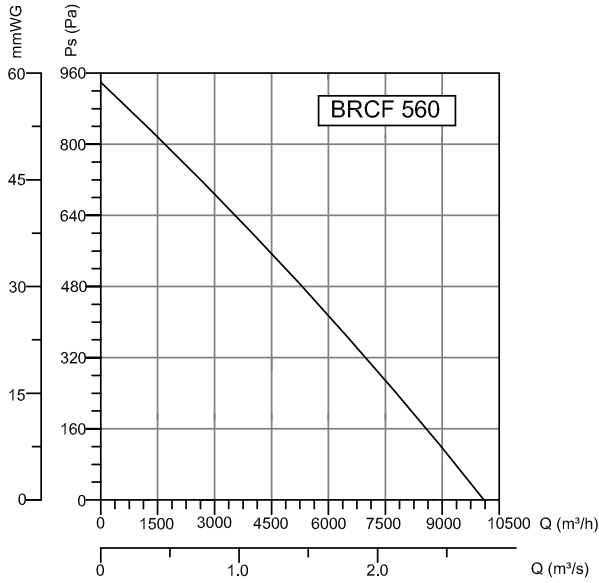
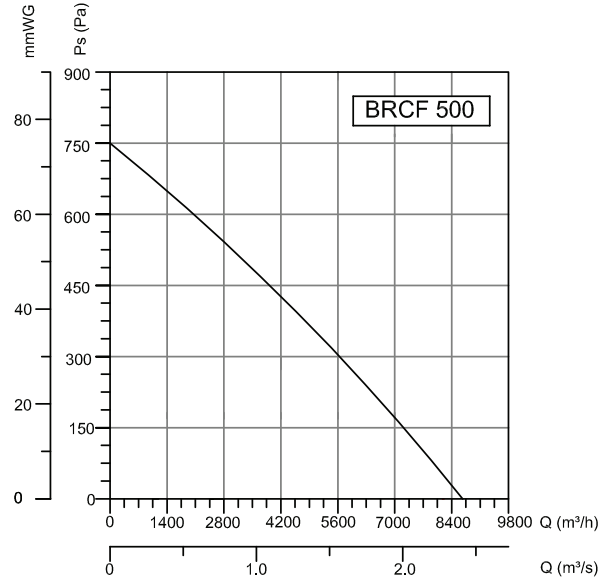
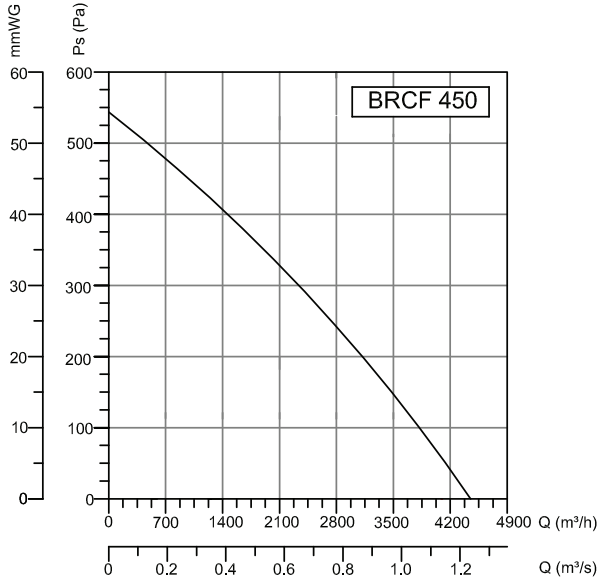



KANAL FANLARI

ÇATI FANLARI

AKSIYEL FANLAR

RADYAL FANLAR

PLASTİK FANLAR

VANTİLATÖRLER

DUMAN EGZOST  
SİSTEMLERİ

AKSESUARLAR